

BOOM LIFT CYLINDER ADAPTER KIT

When an excavator's priority is lift height, not digging depth, the WBM Boom Lift Kit offers an excellent solution. Once added to a machine, the excavator's lift height is increased due to the positive effect in geometry.

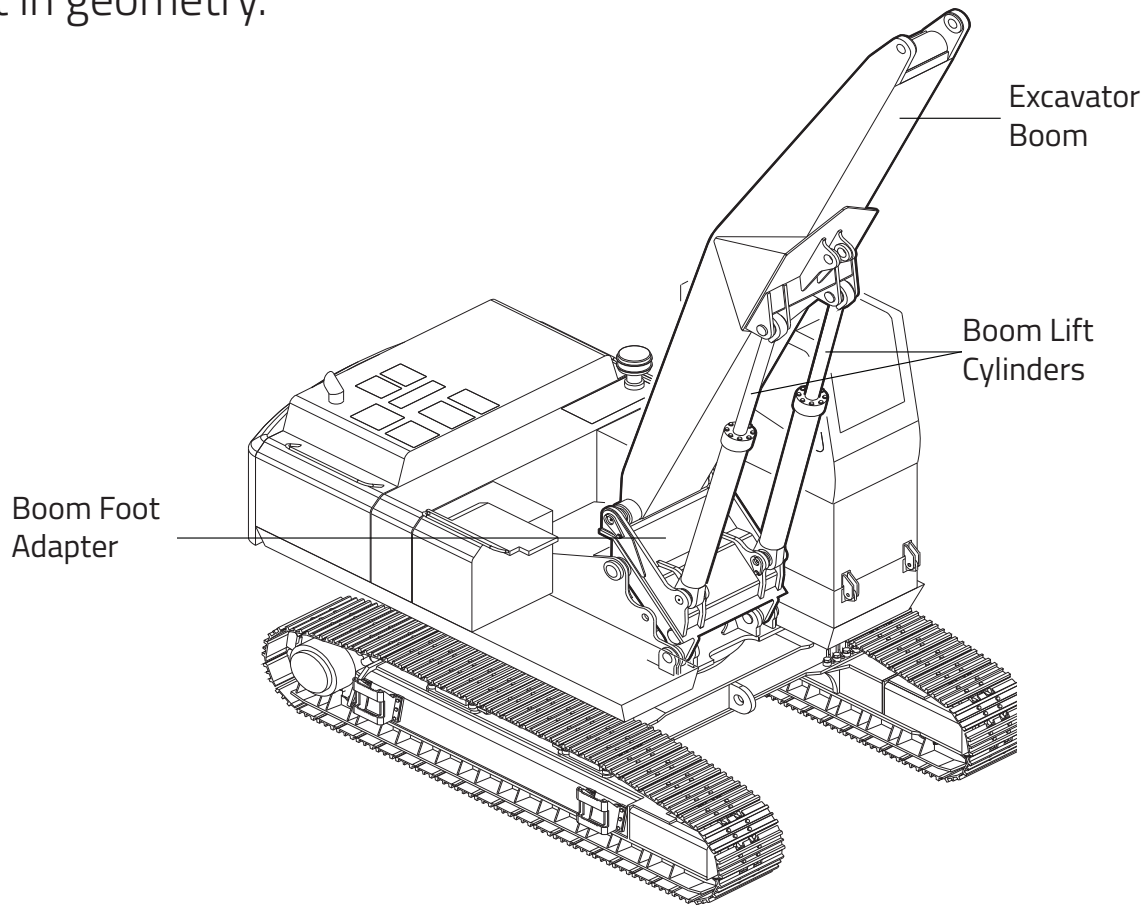

FEATURES & BENEFITS

- Easy installation
- Pin-on or weld-on design
- Design specific to application
- A low cost addition to an excavator that adds reach height to an excavator without having to purchase a longer boom or stick
- Utilizes OEM pins
- Increased lift height