

BUTT-N-TOP GRAPPLE



WBM's Butt-n-Top Grapples load, unload, sort and pile tree length wood with a log loader or standard excavator machine configuration.

FEATURES & BENEFITS

- Individually controlled hydraulic outriggers stabilize load
- Strong light weight body
- Large diameter pins for greater durability
- Powerful sorting or bunching jaws
- 360° continuous rotation
- Totally enclosed for internal component protection
- Enables loading from the side or front
- Outriggers provide easier level loading
- Maximum productivity of excavator/log loader

STANDARD EQUIPMENT

- Tilt cylinder turret
- Pivot frame
- High pressure heavy-duty cylinders
- Two outriggers
- High pressure swivel
- Pin-on lugs
- Rugged, high torque motors
- *FlexDrive* system

OPTIONS

- Valve-in-head
- V or U shaped outriggers
- Bunching or Sorting jaws
- Bucket linkage lugging
- Shortwood jaw option
- Extended tool cylinder to use factory cylinder anchor with removal of bucket linkage
- Tilt cylinder and cylinder anchor



Continued on next page >>

FEATURES AND SPECIFICATIONS

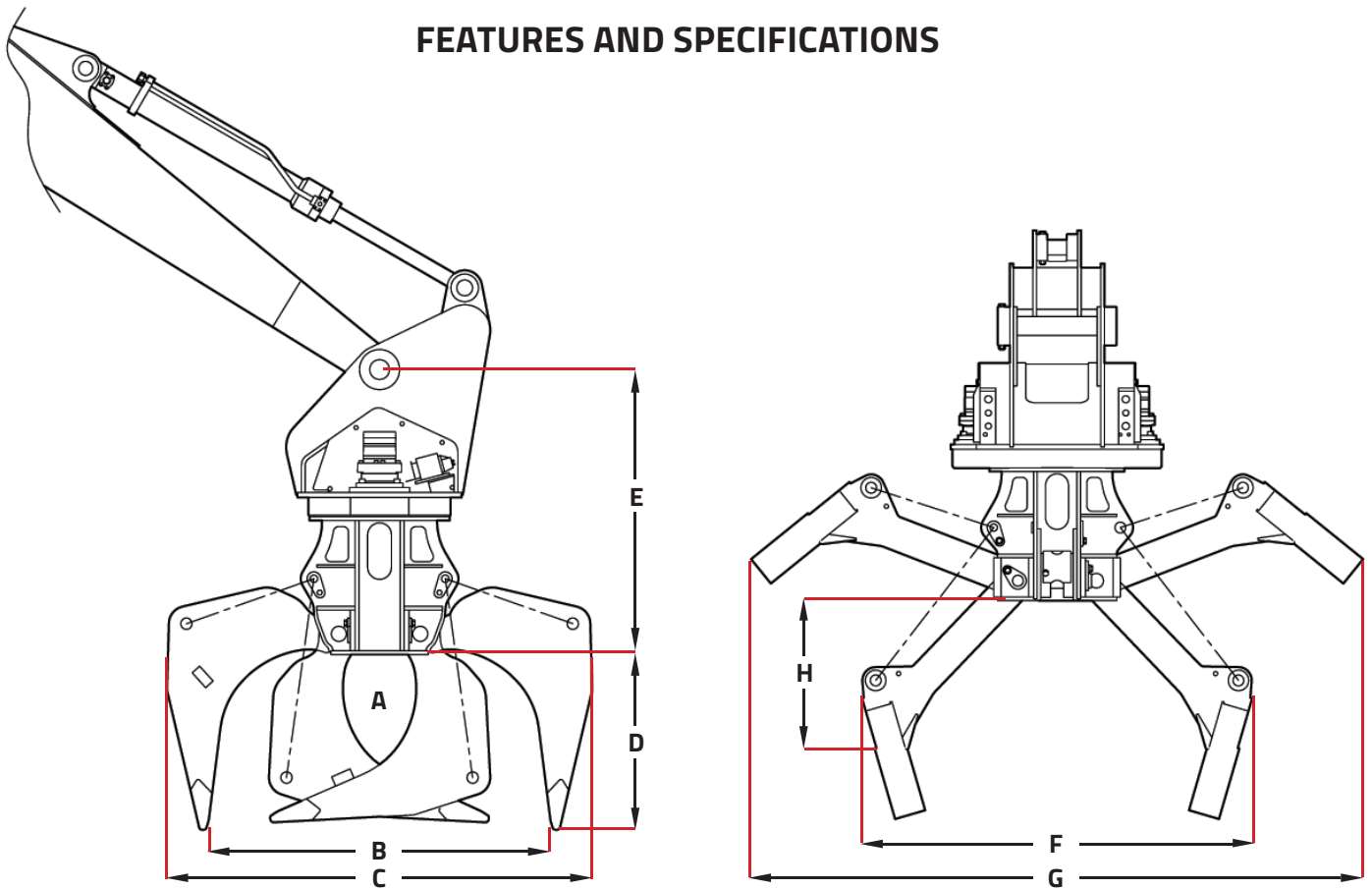

DIMENSIONS (INCHES)

MODEL	CAPACITY (sq. ft.)	A	B	C	D	E	F	G	H	BEARING
XG 300 S	3.10	14	46	69	22	40	70	116	24	Small Bearing Chassis
XG 400 B	4	15	52	74	27	41	70	116	24.5	
XG 500 B	5	18	68 5/8	86	30.5	50	81.5	127	31	Medium Bearing 27" Chassis
XG 500 S	5.1	14	65	91	34	50	81.5	127	31	
XG 600 B	6.25	19	69.5	91	34	50	87.5	127	31	
XG 600 S	6.27	15.5	68	87	33	50	87.5	127	31	
XG 600 B	7.08	19	76 5/8	-	-	50	81.5	127	31	
XG 600 S	7.04	15 3/8	73 3/16	-	-	50	81.5	127	31	
XG 600 B	8	19.5	81 5/16	-	-	50	81.5	127	31	
XG 600 S	8	15.5	78 5/6	-	-	50	81.5	127	31	
XG 700 B	8.1	25	77	103	38.5	50.5	89	150	31	Large Bearing 34.4" Chassis
XG 800 B	8.7	25 3/16	75	103	39	52	89	150	31	
XG 800 S	8.8	20 3/4	75	103	44 3/16	52	89	150	31	
XG 900 B	12.5	31 3/8	84 3/4	-	-	52	89	150	31	

Weights and specifications are approximate and are subject to change without notice.