

HEEL GRAPPLE



WBM's Heel Grapple is specifically designed for loading, sorting, decking, and hoe-chucking (shovel logging/ forwarding) tree length wood.

FEATURES & BENEFITS

- High strength alloy steel used throughout for maximum durability and service life
- Low profile jaw design for easier penetration of log piles
- Improved jaw open/close range to handle large and small diameter wood
- Integral Single Plate cylinder anchor mounting for exceptional strength and reduced maintenance & repair expense
- Large side opening provides easy access for maintenance of components

STANDARD EQUIPMENT

- Heavy duty bearing and gear drive system with continuous 360° rotation
- Motor equipped with cross over relief valves for protection against externally applied loads
- Heavy Duty guards to protect hydraulic motor, hose and cylinder protection
- Hanger link/ knuckle
- Heavy duty by-pass jaws with dual hinge pins

OPTIONAL EQUIPMENT

- Live heel/Cylinder
- Complete logging fronts
- Machine guarding/conversions
- Available in various jaw configurations and sizes

Continued on next page »

FEATURES

DIMENSIONS

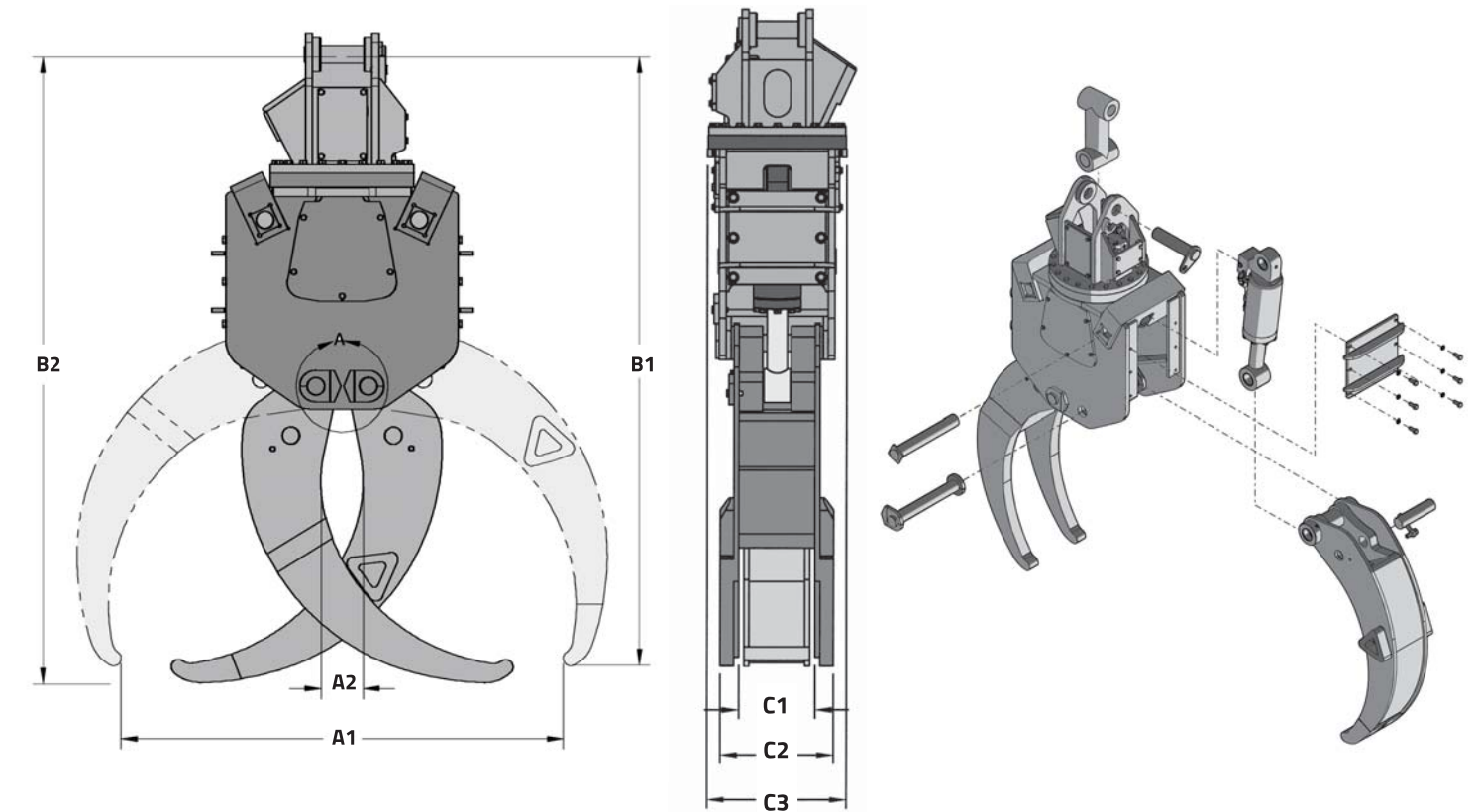
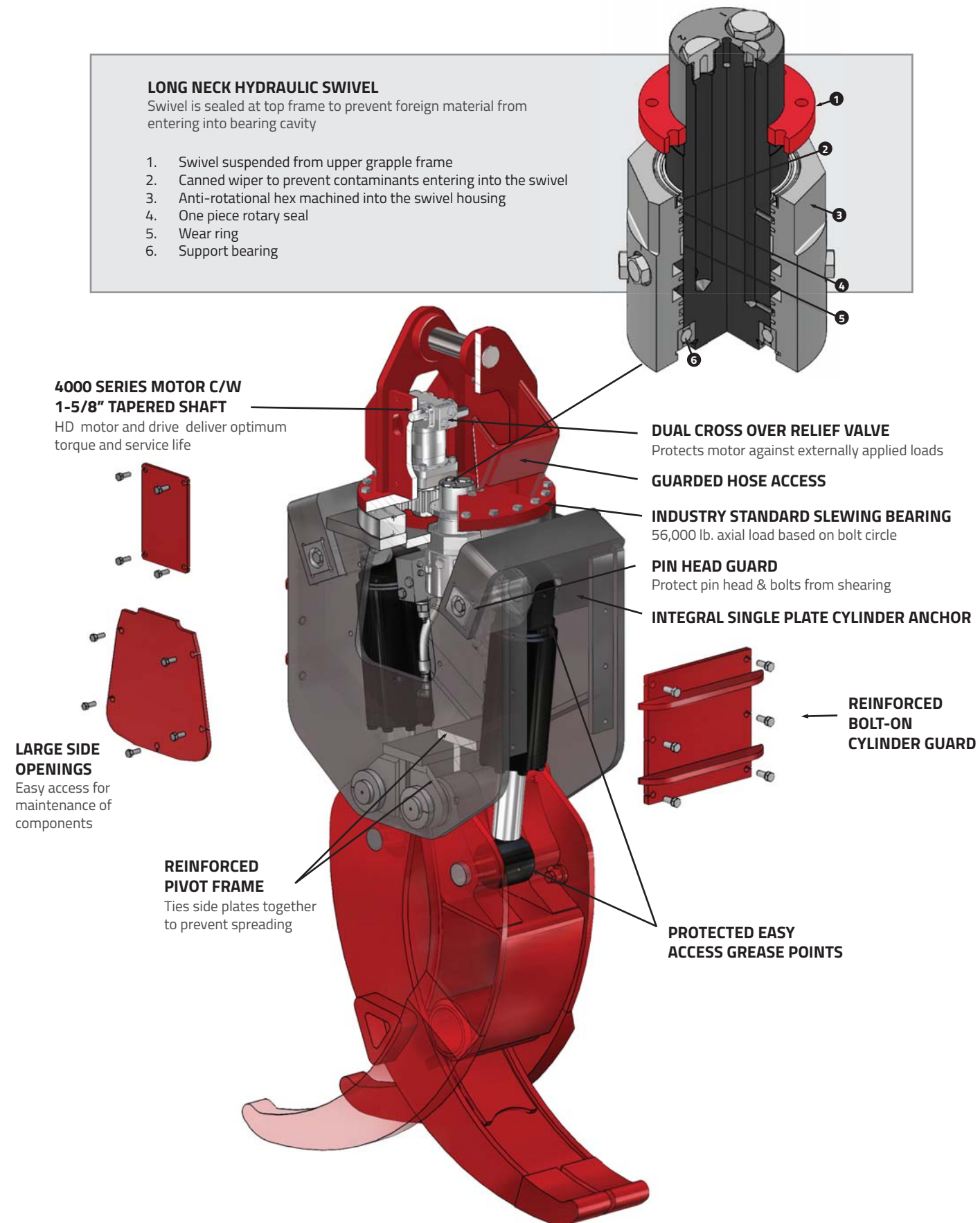

GRAPPLE SIZE	52"	60"	63"	66"	72"
Open Capacity <i>(Calculated based on Tip-to-Tip Configuration)</i>	3.66	5.68	5.96	6.23	6.78
A1 - Open	52"	60"	63"	66"	72"
A2 - Closed	4-1/4"	7"	6"	7"	7"
B1 - Height Open	82-1/8"	81 - 1/2"	81 - 1/2"	83 - 1/16"	86 - 1/2"
B2 - Height Closed	80"	84 - 3/4"	84 - 3/4"	88 - 3/8"	93"
C1 - Inside Jaw Width	9"	11 - 1/4"	11 - 1/4"	11 - 1/4"	11 - 1/4"
C2 - Outside Jaw Width	14-1/4"	16 - 3/4"	16 - 3/4"	16 - 3/4"	16 - 3/4"
C3 - Body Width	20-5/8"	20 - 5/8"	20 - 5/8"	20 - 5/8"	20 - 5/8"
Weight (lbs)	2,400	3,000	3,600	3,700	3,800

Other jaw sizes available.
Estimated specifications; subject to change without notice.



WBM **WELDCO-BEALES MFG.**
SPECIALISTS IN ATTACHMENT DESIGN AND MANUFACTURING
www.weldco-beales.com

Western Canada: 1 800 665 0511
Central Canada: 1 800 661 4155
Eastern Canada: 1 877 320 4286

Last revised: February 26, 2019