

# UNI-BEAM PIPE GRAPPLE

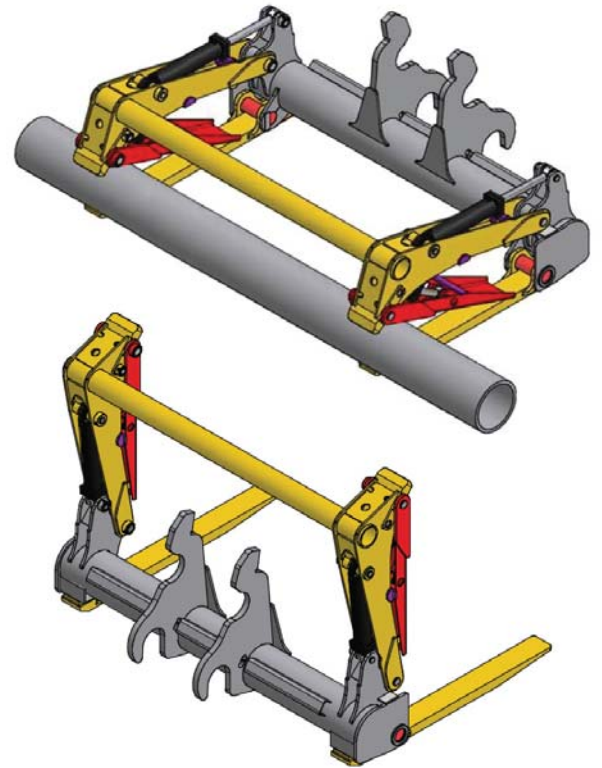

## FEATURES

- Turns a swing machine into a telehandler to go where fork-lifts cannot
- Hoe chuck over very wet and rough terrain
- Low profile Uni-Beam frame design drastically improves operator visibility over industry standard twin beam fork frame.
- 96 inch standard carriage width
- In-frame hose routing
- Light weight
- Fixed tine location
- Fork tine kick-outs
- (2) 4 inch diameter clamp and (2) 3 inch diameter stabilizer hydraulic cylinders
- 12 inch maximum pipe

## OPTIONS

- Safety cam on quick change lugs
- Adjustable tines
- Fork positioner locks
- Custom widths
- Dual taper tines
- Variable tine sizes and lengths
- Holding valve to limit clamping force but not decrease the stabilizing force (increases rated load)
- Clamp and stabilizer to handle smaller or larger pipe diameters