

# PEELER FORK

WBM Peeler Forks are designed for transporting 8' wood from the debarking or slashing operation to the steam chambers in a plywood mill application.

## FEATURES AND BENEFITS

- Heavy-duty box type construction
- Tapered box tine with weld-on replaceable tip
- High back design
- WLKAT or OEM pin-on lugs
- Excellent durability and rigidity supplies load stability
- Tapered curve design has excellent loading characteristics
- High back design increases payload and provides excellent visibility
- Sized to suit machine

## OPTIONS

- Ejector assembly to increase log unloading capabilities
- Overarm assembly to increase payload capacity and load stability
- Bolt-on reversible cutting edge
- Hard surface welding to promote wear life
- High lift lugs for high reach capabilities
- Pin-on replaceable fork tine design also available

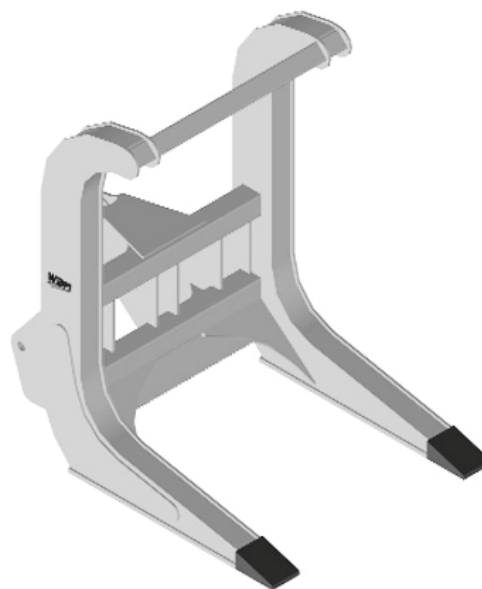

**WELDCO-BEALES MFG.**

SPECIALISTS IN ATTACHMENT DESIGN AND MANUFACTURING

[www.weldco-beales.com](http://www.weldco-beales.com)