

STRAIGHT BLADE

WBM Wheel Loader Straight Blades are used in numerous applications where dozing, grading or general clearing is required. Applications range from snow removal to stockpiling to road building. The straight blade configuration enables the operator to pitch a blade forward or back to alter the grading or cutting ability of the blade.

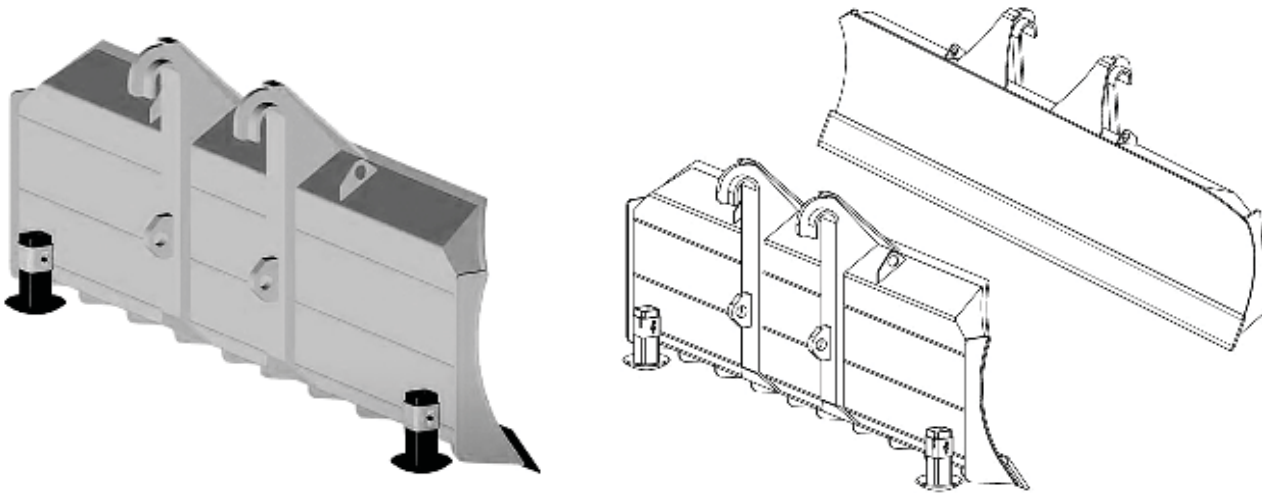

FEATURES AND BENEFITS

- Proven and tested moldboard profiles
- Maximum blade widths and heights to match application and machine capability
- Adjustable skid shoes
- Center drilled reversible bolt-on edges
- Available with WLKAT or OEM pin on lugs
- Economical solution for basic grading, plowing or dozing
- Moldboard profiles provide optimum material 'rolling' or carry characteristics
- Increases productivity of machines by matching maximum width and height to application
- Skid shoes increase cutting edge wear life and grading characteristics

STANDARD EQUIPMENT

- Bolt-on reversible cutting edges to promote wear life of the blade

OPTIONS

- Wear resistant cutting edges (i.e. carbide) for extreme high wear conditions
- Available in a wide range of widths and heights depending on the application