

UNI-BEAM MAT GRAPPLE

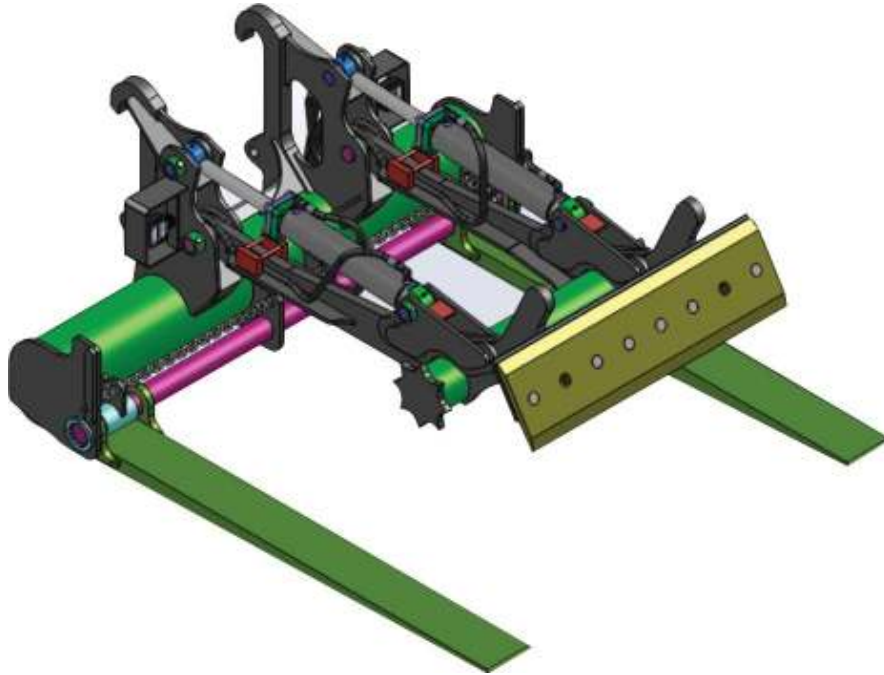

FEATURES

- Low profile Uni-Beam frame design drastically improves operator visibility over industry standard twin beam fork frame
- 80" standard carriage width
- Light weight
- Adjustable tine location
- Fork tine kick-outs
- (2) 4" diameter clamp hydraulic cylinders
- Clamp limits grapple to (3) mats maximum capacity
- Two point contact for clamp allows pincher grabbing at tine tips or mid-point to hold down mats when carrying
- Cutting edge on clamp allows scraping or cleaning of mats
- (2) LED lights
- Clamp mechanical stops prevents over extending of hydraulic cylinders

OPTIONS

- Fork positioner locks
- Custom widths
- Dual taper tines
- Variable tine sizes and lengths
- Holding valve to limit clamping force but not decrease the stabilizing force (increases rated load)
- Clamp and stabilizer to handle more than (3) mats

