

CTL DANGLE-HEAD GRAPPLE (NON BY-PASS)



WBM's CTL Dangle-Head Grapples are primarily used in high decking applications and loading/unloading cut-to-length wood in the bush or mill yard.

FEATURES AND BENEFITS

- High strength alloy steel used throughout for maximum durability and service life
- Proven jaw profile maximizes capacity, increases productivity, reduces loading cycles and allows for easier penetration of log piles
- HD pivot frame provides exceptional strength for reduced maintenance & repair expense
- Large bottom opening provides easy access for maintenance of components
- Fully supported Swivel core with a one-piece rotary seal for optimum durability
- One piece horseshoe jaw cylinder anchor for maximum strength

STANDARD EQUIPMENT

- Heavy duty bearing and gear drive system with continuous 360° rotation
- Motor equipped with cross over relief valves for protection against externally applied loads
- Heavy duty (Tip-to-Tip non-bypass) jaws with dual hinge pins and timing gears
- Heavy duty small load retainer (hold-down) chains
- Two configurations available: by-pass or non by-pass (tip-to-tip)
- Cylinder complete with cushions in the open and closed position

OPTIONAL EQUIPMENT

- Available in various jaw configurations and sizes to suit machine and application
- Heavy duty butt plate to protect hydraulic motor, hose and cylinder
- Hanger link/ knuckle
- Bolt-on cutting edges
- Timed jaws

OTHER WBM FORESTRY PRODUCTS

- Complete logging fronts
- Machine guarding/ forestry conversions

Continued on next page »

LONG NECK HYDRAULIC SWIVEL

Swivel is sealed at top frame to prevent foreign material from entering into bearing cavity

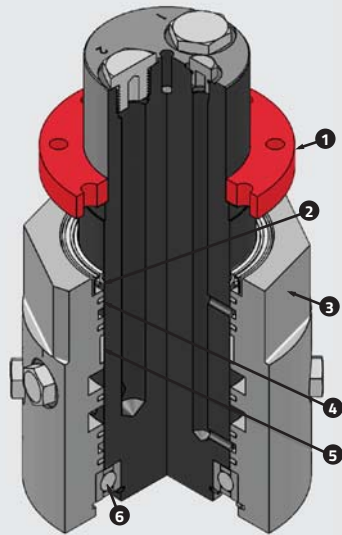

1. Swivel suspended from upper grapple frame
2. Canned wiper to prevent contaminants entering into the swivel
3. Anti-rotational hex machined into the swivel housing
4. One piece rotary seal
5. Wear ring
6. Support bearing

EATON CHAR LYNN 4000 SERIES MOTOR C/W 1-5/8" TAPERED SHAFT

Eliminates shaft breakage due to rapid reversals

EATON DUAL CROSS OVER RELIEF VALVE

Protects motor against externally applied loads

OPTIONAL BUTT / LEVELING PLATE

FULLY MACHINED TIMING GEAR

PROTECTED PIN EARS

HEAVY DUTY COVER DOOR

ONE-PIECE "HORSESHOE" BOSS
For maximum strength

HEAVY-DUTY LOAD CHAINS

BOX SECTION JAW DESIGN
Lightweight yet strong

COMMON WBM COMPONENTS
(Ex. cylinders, pins)

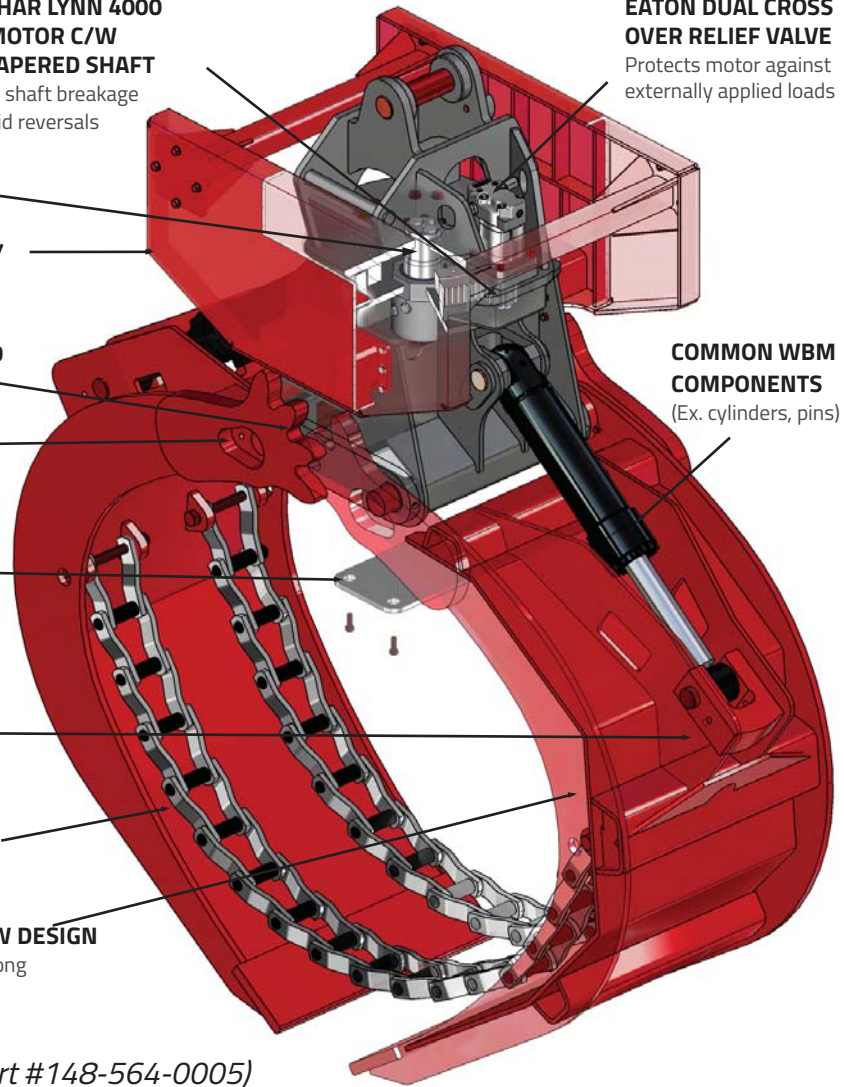

MODEL SHOWN: EX300-CTL 21 NB (WBM Part #148-564-0005)

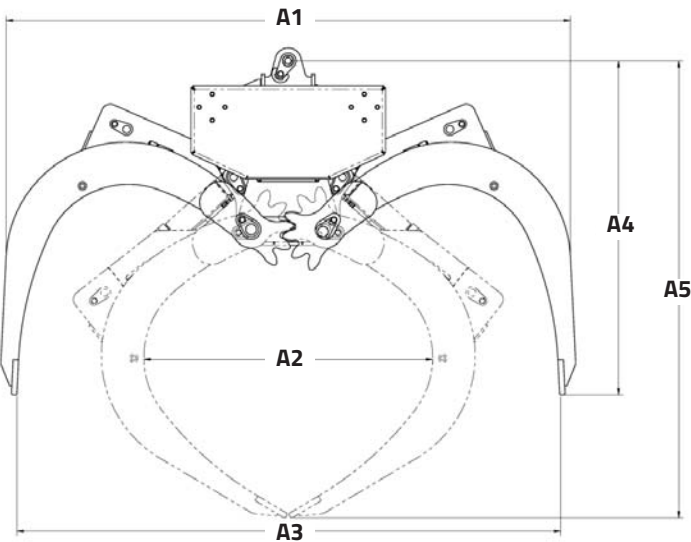

GRAPPLE CAPACITY (TIP-TO-TIP)	21 Ft ² / 1.95m ³
A1 - Max. Outside Width - Open	129.6" / 3294 mm
A2 - Min. Inside Width - Closed	66.3" / 1686mm
A3 - Min. Inside Width - Open	125" / 3175mm
A4 - Drop Height Open	76.8" / 1950mm
A5 - Drop Height Closed	105.1" / 3670mm
B1 - Body Width	34.5" / 876mm
B2 - Jaw Width	29.5" / 750mm
Weight (Includes Butt Plate)	4655 lbs

Other jaw sizes available.