

HYDRAULIC WEDGE COUPLER



The WBM Hydraulic Wedge Coupler incorporates enhanced safety systems, positive release performance and engineered lifting capabilities.

FEATURES & BENEFITS

- Reinforced frame for greater lifting capacity
- Certified lifting eye sized to match the appropriate clevis or shackle pin.
 - Prevents overloading the coupler and lifting eye
 - Allows lifting loads directly with the coupler without the added weight of the attachment
- Large high pressure release cylinder
- Three level safety lock system
- Audible and visible warnings in operators cab when wedge bar is disengaged
- Can be used with attachments in the same weight class designed for manual couplers

WEDGE BAR OPERATION SWITCH

Equipped with safety cover on switch, audible alarm and warning light.



RELEASE POSITION

- Alarm audible
- Warning light on
- Wedge Bar disengaged

ENGAGE POSITION

- Alarm off
- Warning light off
- Wedge Bar engaged

Continued on next page >>

THREE LEVEL SAFETY LOCK SYSTEM

Prevents accidental disengagement of the coupler and attachment.

1. Manual locking pin and retainer
2. Release cylinder with lock valve
3. Compression engagement springs

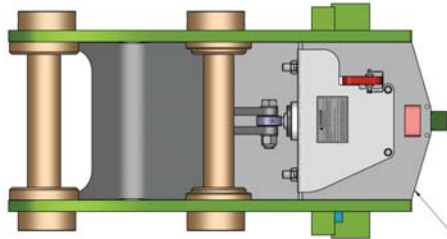

ENCLOSED DESIGN TO REDUCE MATERIAL BUILD UP

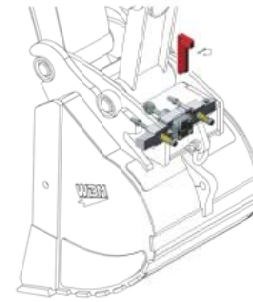
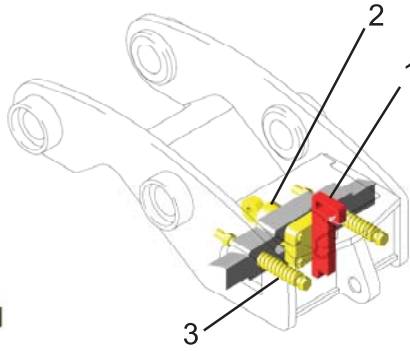

Wedge Bar Disengaged From Attachment

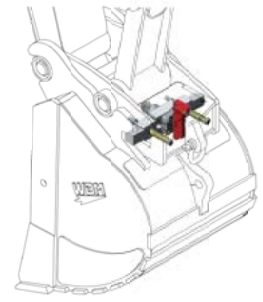

Wedge Bar Engaged With Attachment

SAFETY LOCK AND RETAINING PIN

FIRST SAFETY LOCK

- Positive locking to prevent accidental disengagement of the wedge bar.

HEAVY DUTY RELEASE CYLINDER

SECOND SAFETY LOCK

- Lock Valve: Holds pressure in the cylinder if there is a drop in system pressure, maintaining wedge bar engagement.
- Machine (high) pressure to disengage wedge bar from attachment.
- Constant pilot (low) pressure to engage wedge bar with attachment. Reliable engagement and disengagement of attachments.

COMPRESSION SPRINGS

THIRD SAFETY LOCK

- Powerful engagement springs: Positive spring pressure on wedge bar gives our coupler a "normally engaged configuration".

INTERCHANGEABLE

- With attachments built for manual style couplers (within the same weight class).
- Maximize use of current attachment inventory with no additional cost.

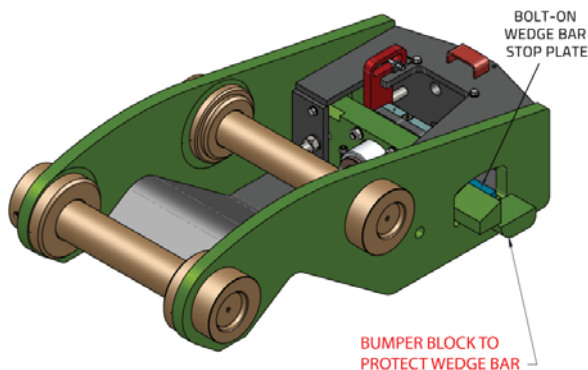

DOUBLE ACTING CYLINDER WITH LOCK VALVE
CYLINDER DIRECTLY PINNED TO WEDGE BAR

